



# Valve Regulated Lead-Acid Rechargeable Battery

## EP40-12



The battery is constructed by plates, separators, safety valves and container. Since the electrolyte is held by a glass-mat separator and plates, the battery can be used in any direction and position without leakage.

### PERFORMANCE SPECIFICATIONS

Nominal Voltage(V).....	12 volts(6cells in series)
Nominal Capacity(Ah)	
20 Hour rate F.V.(1.75V/cell) (2000mA to 10.50volts) .....	40.0Ah
10 Hour rate F.V.(1.75V/cell) (3800mA to 10.50volts) .....	38.0Ah
5 Hour rate F.V.(1.75V/cell) (6800mA to 10.50volts) .....	34.0Ah
30 Min rate F.V.(1.30V/cell) (40000mA to 7.80volts).....	20.0Ah
Approximate Weight.....	14500g(31.97lbs.)
Terminal	
Standard.....	Type B2
Optional.....	Type I1, I2
Internal Resistance (Fully Charged Battery).....	<8m Ω
Maximum Discharge Current For 5 sec.(A).....	600A
Maximum Charge Current(A).....	12A
Ambient Temperature	
Charge.....	0°C(32°F)~40°C(104°F)
Discharge.....	-20°C(-4°F)~50°C(122°F)
Storage.....	-20°C(-4°F)~40°C(104°F)
Vibration test:	
Frequency: 16.7Hz	
Amplitude: 4mm	
Vibrate the battery horizontally or vertically for 60 minutes. The battery have no abnormality.	
Case.....	ABS
Dimension(mm/inch)	
Length           ±1.5mm.....	197/7.76
Width           ±1.5mm.....	165/6.50
Container Height ±1.5mm.....	171/6.73
Total Height   ±1.5mm.....	171/6.73
Application.....	Wheelchairs, Lawn Mowers, Electric Vehicles, Golf-Carts.

## EP40-12 Battery discharge characteristics (25 °C/77 °F)

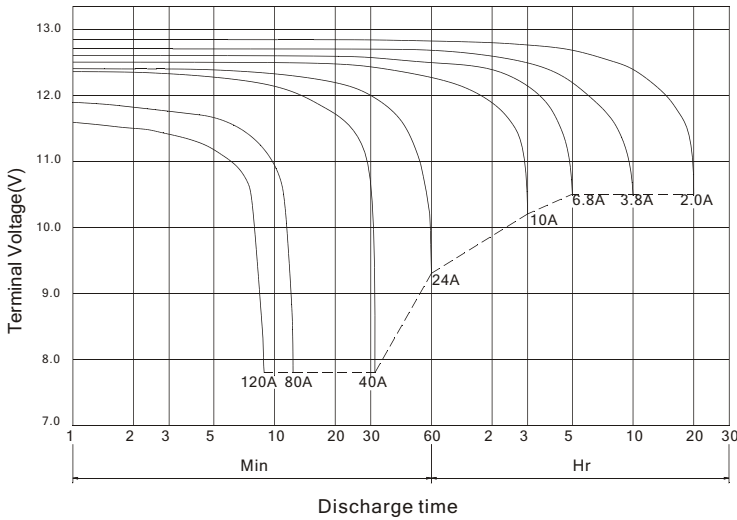

## Battery Charging Characteristics

(Typical example of the charge characteristics for the cycle use)

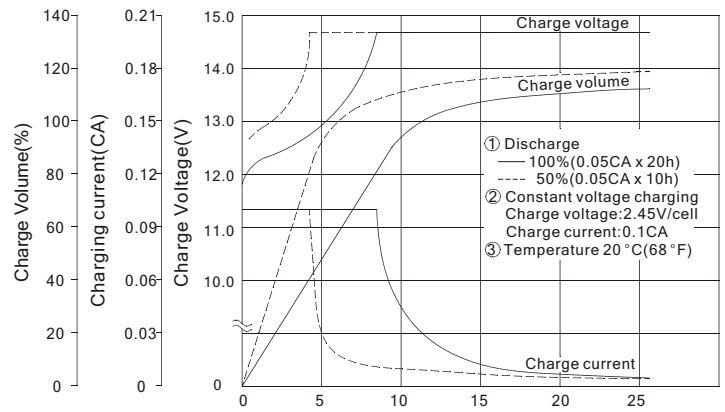

## Battery Life Characteristics of Cyclic Use

Testing Conditions : Discharge Current : 0.25C Amp (F.V. : 1.7v/cell)  
 Charging Current : 0.1C Amp  
 Charging Voltage : 120% OF Discharge Capacity  
 Ambient Temperature : 20 °C (68 °F)

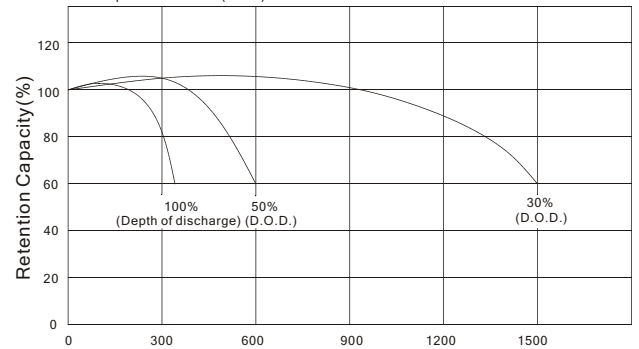

## Charging Procedure

Application	Charging method	Charging Voltage at 20 °C (V/cell)	Temperature compensation coefficient of charging voltage (mV/°C/cell)	Max. charging current (CA)	Charging time 0.1CA, 20 °C (h)		Temp (°C)
					100% discharge	50% discharge	
For standby power Source	Constant voltage & Constant current charging (with current restriction)	2.25~2.30	-3	0.3	24	20	0~40 (32~104°F)
For cycle service		2.40~2.50	-4	0.3	16	10	

## OUTER DIMENSIONS mm(inch)

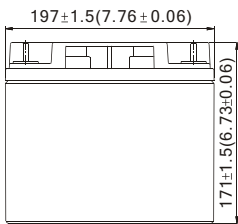
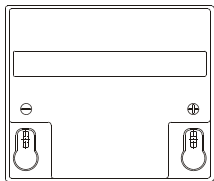

## TERMINAL TYPE mm(inch)

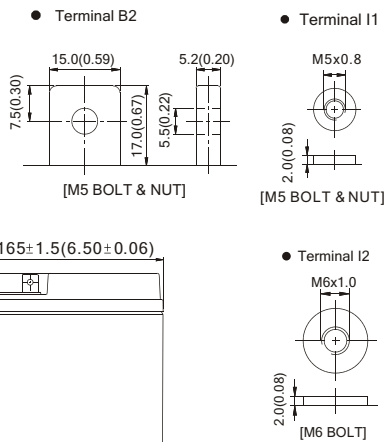

## Constant power discharge characteristics at 25°C/77°F

Final Voltage	Discharge time								
	5Min	10Min	15Min	30Min	1Hr	3Hr	5Hr	10Hr	20Hr
10.80V	1303	979.4	793.1	477.1	276.6	116.6	80.6	44.91	23.49
10.50V	1509	1061.1	830.3	495.4	284.6	118.9	81.7	45.60	24.00
10.20V	1600	1099.4	855.4	506.3	289.7	120.0	82.3	45.83	24.11
9.90V	1674	1125.7	875.4	513.7	293.7	121.1	82.9	45.94	24.17
9.60V	1726	1148.0	892.6	518.9	296.6	121.7	82.9	45.94	24.17

## TERMINAL POSITION

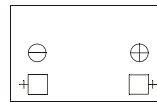

**B.B. BATTERY CO., LTD.**

Web Site: <http://www.bb-battery.com>

**USA:**  
 B&B BATTERY(USA) INC.  
 6415 RANDOLPH ST.COMMERCE,  
 CA,90040 U.S.A.  
 TEL:1-323-278-1900.1-800-278-8599  
 FAX:1-323-278-1268  
 E-Mail:sales@bb-battery.com

**EUROPE:**  
 B&B BATTERY(EUROPE) B.V.  
 3 WIJNGAARDVELD, 9300 AALST,BELGIUM  
 TEL:(00)32-53781567  
 FAX:(00)32-53781567  
 E-Mail:hansdevriese@bb-battery.com

**CHINA FACTORY:**  
 B.B. BATTERY CO., LTD.  
 CHENG DONG TRIAL AREA,HUANG GANG,  
 RAOPING, GUANG DONG,CHINA,515700  
 TEL:86-768-7601001-2  
 FAX:86-768-7601469  
 E-Mail:maggy@bb-battery.com

**HONG KONG:**  
 NATIONAL TRADING LTD.  
 TEL:852-2301-3800  
 FAX:852-2739-1182  
 E-Mail:bbhk@hkstar.com

**JAPAN:**  
 B&B BATTERY(JAPAN) CO., LTD.  
 1375-11 NARAHARA-MACHI,HACHIOJI,  
 TOKYO 193-0803,JAPAN.  
 TEL:81-426-25-6375  
 FAX:81-426-25-6375  
 E-Mail:miyata@bb-battery.com

**TAIWAN:**  
 B.B. BATTERY(TAIWAN) CO., LTD.  
 TEL:886-6-502-5150  
 FAX:886-6-589-8087  
 E-Mail:maggy@bb-battery.com

